

**PHASE SPLITTER  
& POWER AMP  
SECTION**

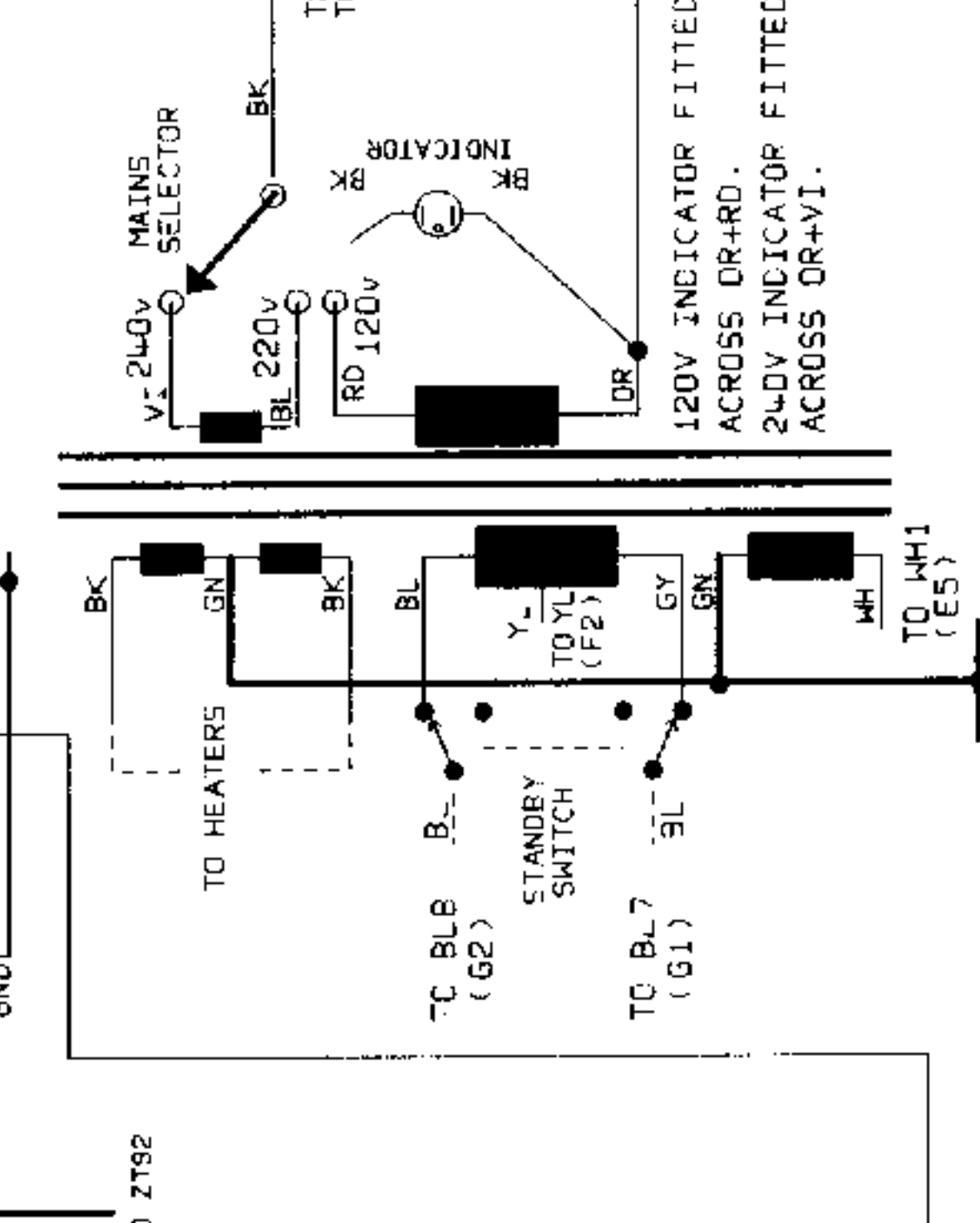

**POWER OUTPUT STAGE**

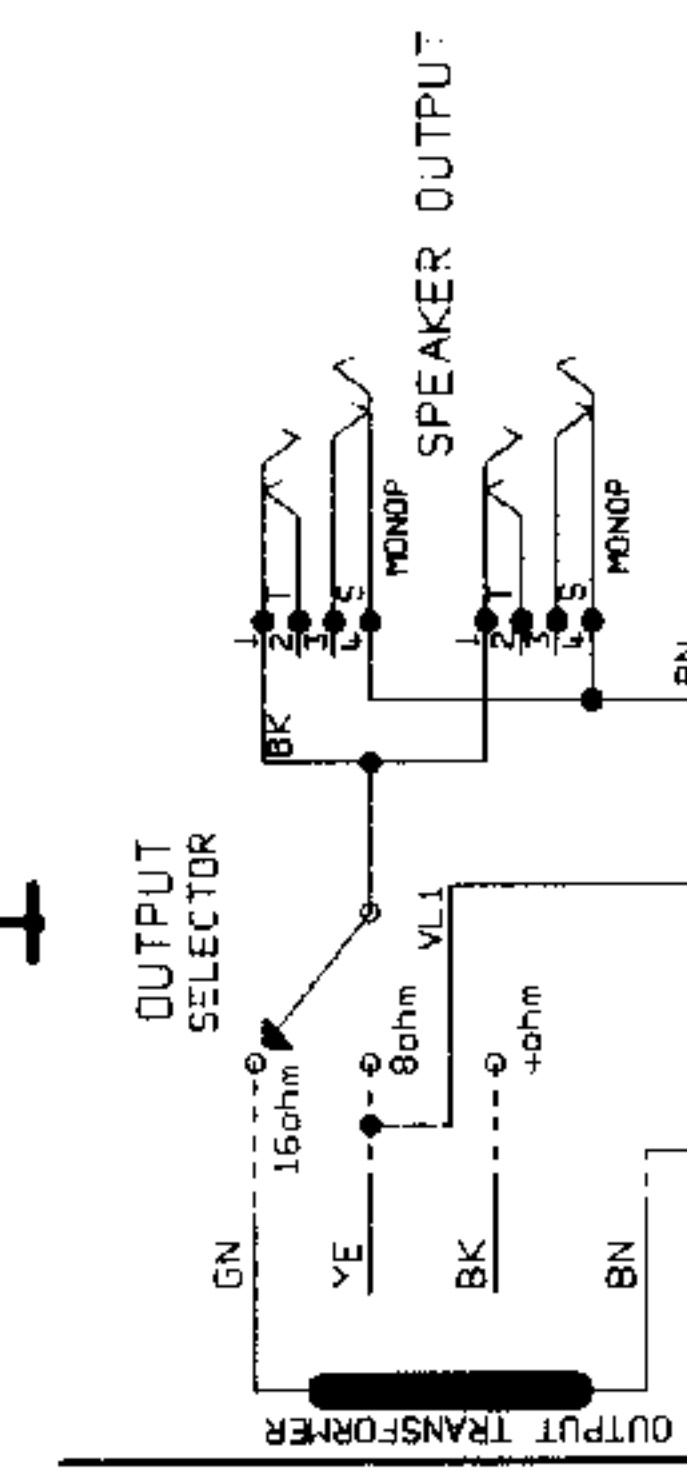
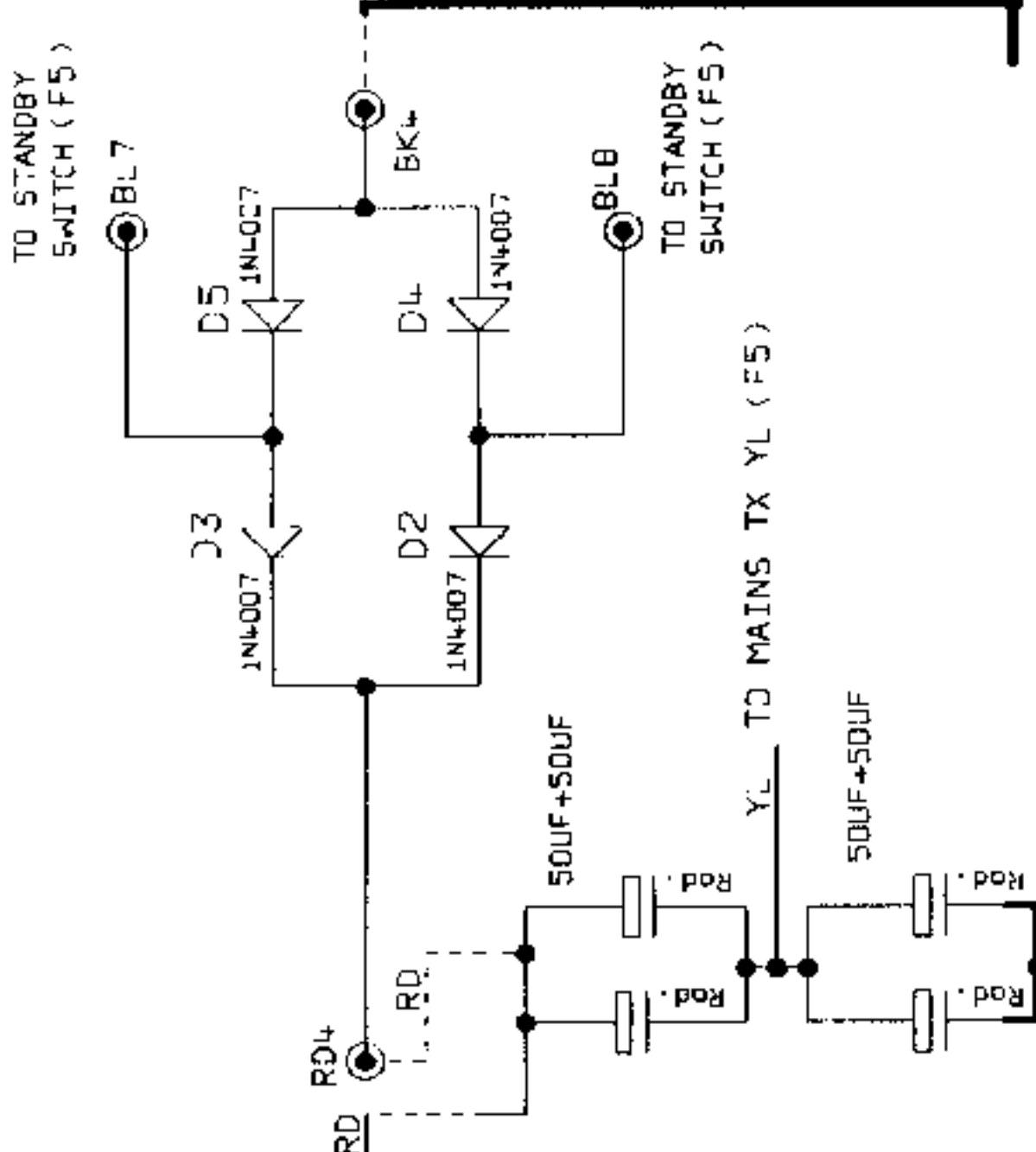
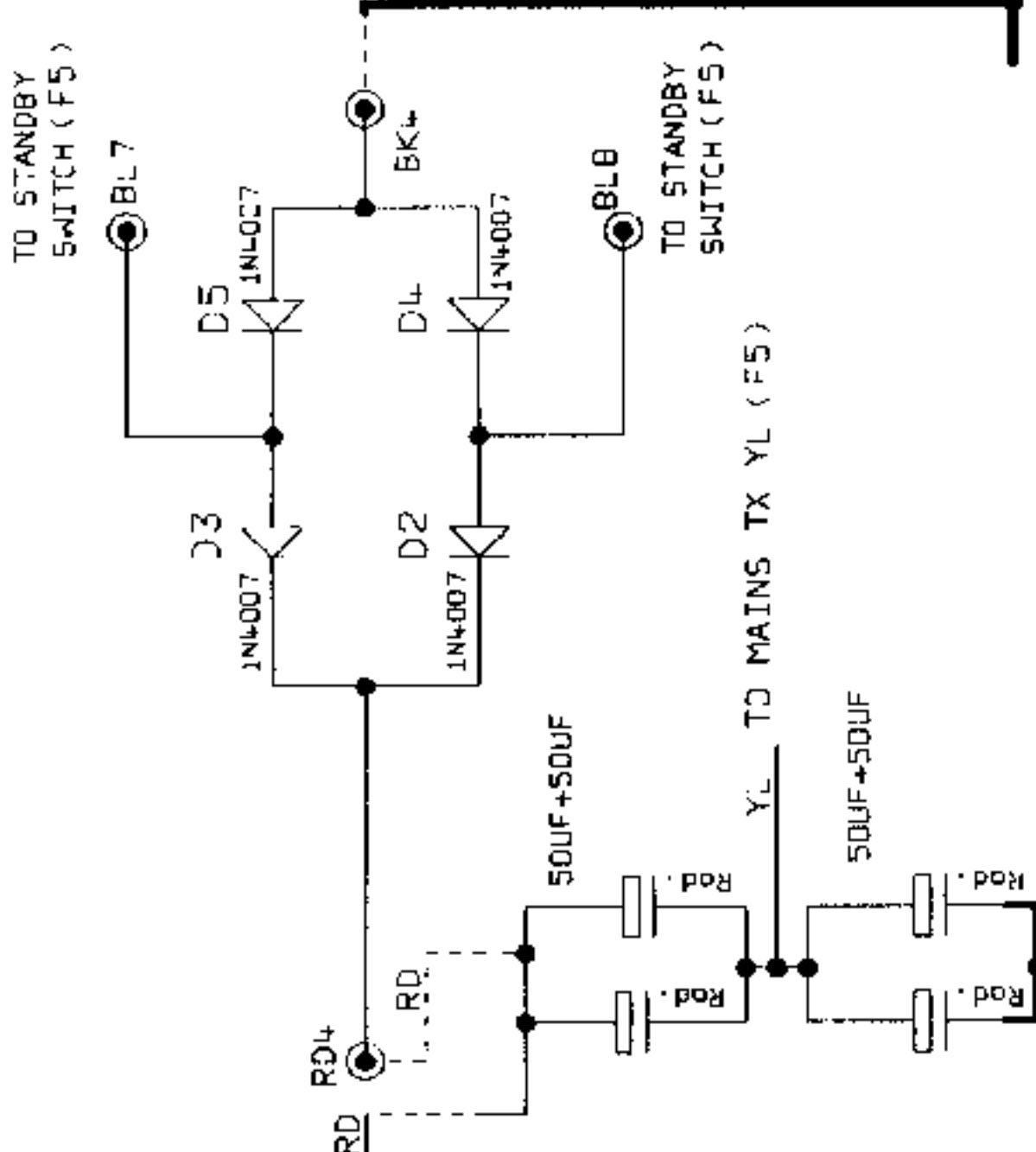
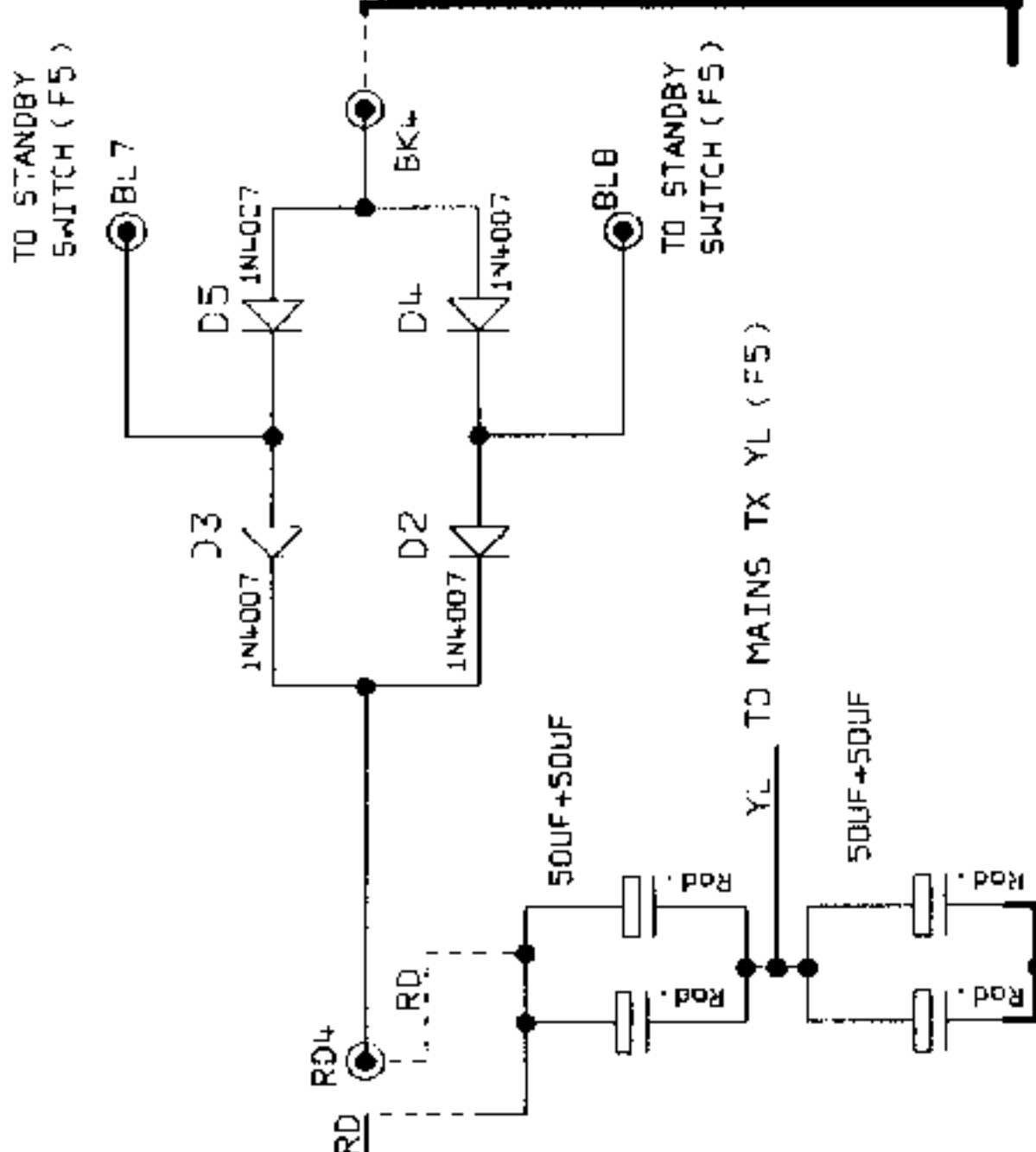

NOTES:  
DASHED LINES DENOTE WIRES OFF FROM THE PCB.  
P2 (A5) - PAGE NC & GRID REF  
GND'S MARKED \* ARE POT-BUS GND

**Marshall**

DIMENSIONS IN		TOLERANCE (UNLESS OTHERWISE STATED)	
MATERIAL THICKNESS	H	INTERNAL BEND RADIUS	J
EXTERNAL BEND R/A	K	CENTRES	L
BEND DIE	M	ANGULAR	N
DRAWN T.F.OY	DATE 28/06/92	CHECKED	DATE
APPROVED	DATE	DATE	DATE

7	0603	18/4/94	A
6	0515	2+1/1/94	B
5	0394	05/8/93	C
4	0348	13/5/93	D
3	0335	19/4/93	E
2	0299	5-2-93	F
1	MANUFACTURE RELEASE	DATE	G
ISS	ECO NUMBER	DATE	

UNSPECIFIED HOLE DATA	
7	H
6	J
5	K
4	L
3	M
2	N
1	P

1959SLP

TITLE  
**CCT DIAGRAM**  
2 OF 2  
DWG. No  
**59X-60-02**  
ISSUE  
**7**

COPYRIGHT EXISTS ON THIS DOCUMENT. IT MUST NOT BE USED FOR ANY PURPOSE  
OTHER THAN THAT FOR WHICH IT IS SUPPLIED AND MUST NOT BE COPIED IN WHOLE  
OR IN PART WITHOUT WRITTEN PERMISSION FROM  
© MARSHALL AMPLIFICATION PLC  
DENISON ROAD, BLETCHLEY, MILTON KEYNES, MK1 1DB.  
TEL: 0529 337541 FAX: 0529 337518